

# PEJO SAFETY HOOKS



## Type C

The PEJO safety hook, type C, provides a safe and reliable way of using your excavator bucket for lifting purposes. The C hook is also suitable for use in different industrial manufacturing applications where safety is a prime concern when lifting. The PEJO safety hooks are made of the highest quality forged steel and can handle loads up to 18 ton.



For excavators  
Type C

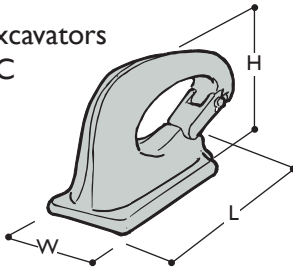

Type	Part No	Repair kit Reparations kit	Max load Ton	L mm	H mm	W mm	Link diam. mm
C201	65101	65301	1,0	105	76	30	21
C202	65102	65302	2,0	130	93	35	25
C203	65103	65302	3,0	133	100	35	25
C204	65104	65304	4,0	177	125	42	38
C205	65105	65304	5,0	185	133	44	40
C206	65106	65304	6,0	198	141	50	40
C208	65108	65308	8,0	250	170	60	45
C210	65110	65308	10,0	255	175	70	50
C215	65115	65308	18,0	290	190	80	50

## Type U

The PEJO safety hook, type U, is recommended for loader applications. Both the C and U locks are equipped with durable, easy to use safety latches which ensure that the lifting device stays in place.



For loaders  
Type U

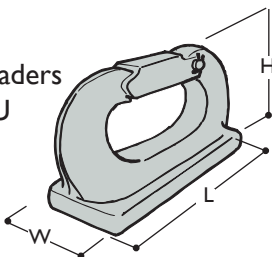

Type	Part No	Repair kit	Max load Ton	L mm	H mm	W mm	Link diam. mm
U200	65200	65400	0,5	95	63	23	20
U201	65201	65400	1,0	105	75	25	23
U202	65202	65402	2,0	123	86	30	28
U203	65203	65403	3,0	145	101	35	31
U204	65204	65403	4,0	152	107	35	31
U206	65206	65406	6,0	205	127	40	43
U208	65208	65406	8,0	216	139	50	43

Combi Wear Parts GmbH  
Mevissenstr.64a  
D-47803 Krefeld  
Tel.: +49 2151 755042  
Fax: +49 2151 755046

[www.combiwearparts.com](http://www.combiwearparts.com)

Combi Wear Parts AB  
Box 205  
681 24 Kristinehamn  
Sverige  
Tel: +46 550 410 550  
Fax: +46 550 410 589



**combi wear parts**  
move the earth

# WELDING MANUAL



## Typ C

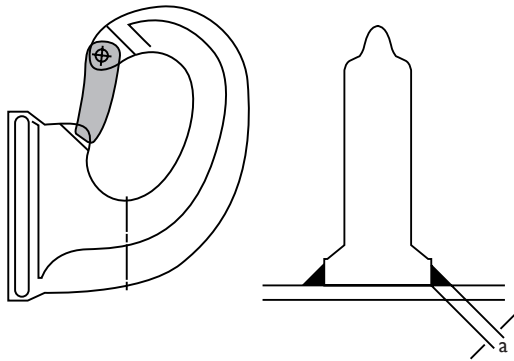

Order no.	Max. load (ton)	Welding throat "a" (mm)
C 201	1	4 (0.15")
C 202	2	4 (0.15")
C 203	3	6 (0.24")
C 204	4	6 (0.24")
C 205	5	6 (0.24")
C 206	6	8 (0.31")
C 208	8	8 (0.31")
C 210	10	8 (0.31")
C 215	18	10 (0.48")

## Typ U

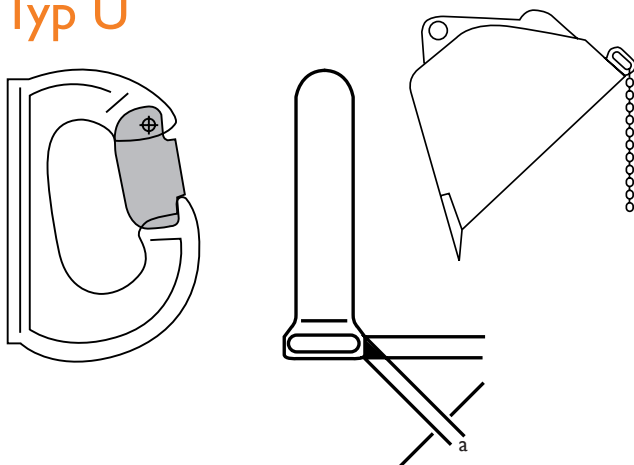

Part no.	Max. load (ton)	Welding throat "a" (mm)
U 200	0.5	4 (0.15")
U 201	1	4 (0.15")
U 202	2	4 (0.15")
U 203	3	6 (0.24")
U 204	4	6 (0.24")
U 206	6	8 (0.31")
U 208	8	8 (0.31")

### Installation

1. It is absolutely essential for the safety hook to be facing the right way when it is welded in position. Turn it so that its largest end will carry the load during lifting operations.
2. Place the safety hook as close to the center-line of bucket as possible.
3. Make sure that the safety hook is located in such a way that it obtains as much protection as possible from link arms and bucket brackets. If the hook is wrongly located, it can be deformed by rocks, etc.
4. For welding works use standard electrode AWS E 7018 (DIN 193:E5153BIO). See the table beside for the welding seam dimension ("a").
5. The Machinery Directive (89/392/EEC) modified states a test factor of 1.5 times the nominal load after welding.

### To be considered when lifting

1. Never overload.
2. Avoid jerks, lift slowly.
3. Ensure that the lifting tackle is correctly located in the lifting hook.
4. Ensure that the lifting tackle cannot slip off the hook.
5. Check the lifting tackle carefully - worn and damaged tools must not be used.
6. The machine should be placed on a firm and stable surface.
7. Observe the safety instructions of the machine.