

PEJO SAFETY HOOKS



Type C

The PEJO safety hook, type C, provides a safe and reliable way of using your excavator bucket for lifting purposes. The C hook is also suitable for use in different industrial manufacturing applications where safety is a prime concern when lifting. The PEJO safety hooks are made of the highest quality forged steel and can handle loads up to 40,000 lbs.



For excavators
Type C

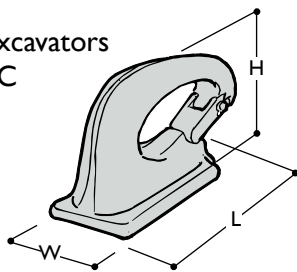

Type	Part No	Repair kit	Max load Lbs	L ins	H ins	W ins	Link diam. ins
C201	65 101	65 301	2 204	4 1/8	3	1 1/4	7/8
C202	65 102	65 302	4 409	5 1/8	3 5/8	1 3/8	1
C203	65 103	65 302	6 613	5 1/4	4	1 3/8	1
C204	65 104	65 304	8 818	7	5	1 5/8	1 1/2
C205	65 105	65 304	11 023	7 1/4	5 1/4	1 3/4	1 5/8
C206	65 106	65 304	13 227	7 7/8	5 1/2	2	1 5/8
C208	65 108	65 308	17 636	9 7/8	6 3/4	2 3/8	1 3/4
C210	65 110	65 308	22 046	10	6 7/8	2 3/4	2
C215	65 115	65 308	39 683	11 3/8	7 1/2	3 1/8	2

Type U

The PEJO safety hook, type U, is recommended for loader applications. Both the C and U locks are equipped with durable, easy to use safety latches which ensure that the lifting device stays in place.



For loaders
Type U

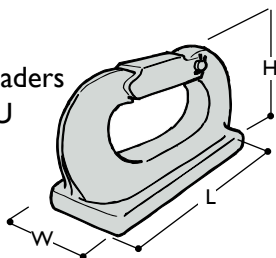

Type	Part No	Repair kit	Max load Lbs	L ins	H ins	W ins	Link diam. ins
U200	65 200	65 400	1 102	3 3/4	2 1/2	7/8	7/8
U201	65 201	65 400	2 204	4 1/8	3	1	7/8
U202	65 202	65 402	4 409	4 7/8	3 3/8	1 1/8	1 1/8
U203	65 203	65 403	6 613	5 3/4	4	1 3/8	1 1/4
U204	65 204	65 403	8 818	6	4 1/4	1 3/8	1 1/4
U206	65 206	65 406	13 227	8 1/8	5	1 5/8	1 3/4
U208	65 208	65 406	17 636	8 1/2	5 1/2	2	1 3/4

Combi Wear Parts INC
363 West Erie street
Suite 100 East, Chicago, IL 60610, USA
Tel: +1 312 482 8103
Fax: +1 312 482 8157

www.combiwearparts.com

WELDING MANUAL



Type C

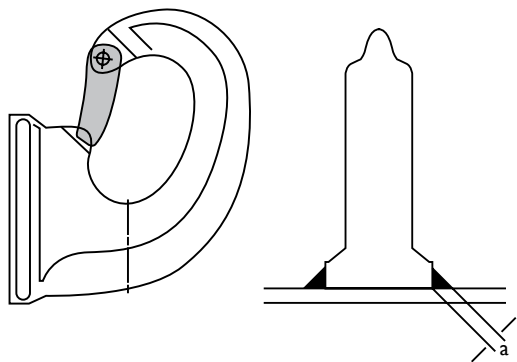

Order no.	Max. load SWL	Welding throat dim. "a"
C 201	1	4 mm (0.15")
C 202	2	4 mm (0.15")
C 203	3	6 mm (0.24")
C 204	4	6 mm (0.24")
C 205	5	6 mm (0.24")
C 206	6	8 mm (0.31")
C 208	8	8 mm (0.31")
C 210	10	8 mm (0.31")
C 215	18	10 mm (0.48")

Type U

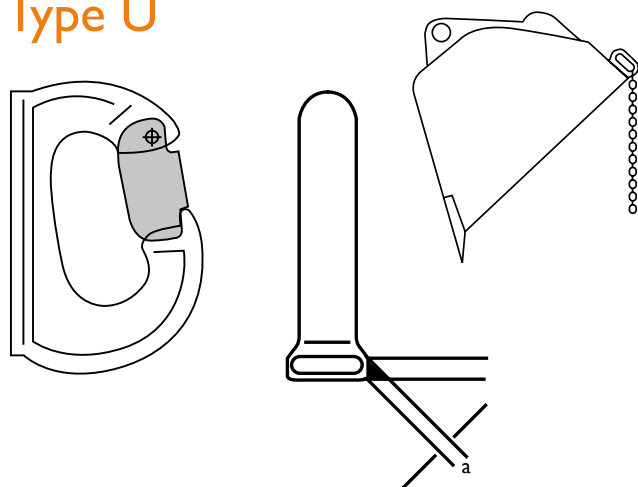

Part no.	Max. load ton	Welding throat dim. "a"
U 200	0.5	4 mm (0.15")
U 201	1	4 mm (0.15")
U 202	2	4 mm (0.15")
U 203	3	6 mm (0.24")
U 204	4	6 mm (0.24")
U 206	6	8 mm (0.31")
U 208	8	8 mm (0.31")

Installation

1. It is absolutely essential for the safety hook to be facing the right way when it is welded in position. Turn it so that its largest end will carry the load during lifting operations.
2. Place the safety hook as close to the center-line of bucket as possible.
3. Make sure that the safety hook is located in such a way that it obtains as much protection as possible from link arms and bucket brackets. If the hook is wrongly located, it can be deformed by rocks, etc.
4. For welding works use standard electrode AWS E 7018 (DIN 193:E5153BIO). See the table beside for the welding seam dimension ("a").
5. The Machinery Directive (89/392/EEC) modified states a test factor of 1.5 times the nominal load after welding.

To be considered when lifting

1. Never overload.
2. Avoid jerks, lift slowly.
3. Ensure that the lifting tackle is correctly located in the lifting hook.
4. Ensure that the lifting tackle cannot slip off the hook.
5. Check the lifting tackle carefully - worn and damaged tools must not be used.
6. The machine should be placed on a firm and stable surface.
7. Observe the safety instructions of the machine.